

GUTTER SPIKES

VEXO Gutter Spikes are a revolutionary solution for safeguarding your gutters against avian pests.

Crafted from durable stainless steel, these spikes provide long-lasting protection against debris accumulation caused by perching and nesting.

As an innovative addition to your property, our Gutter Spikes offer a seamless integration into your gutter system, ensuring a secure and bird-free environment.

Upgrade to a hassle-free and effective solution with VEXO Gutter Spikes, the ultimate choice for maintaining clean and functional gutters while deterring avian nuisances.



GX21

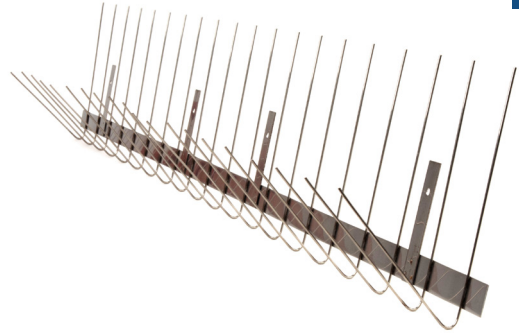

GX33

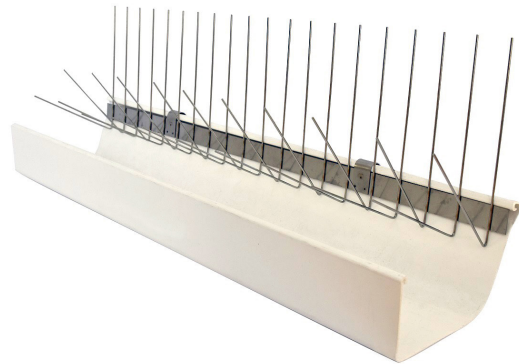

INTERGRATED MOUNTING TAB

VEXO Gutter Spikes are designed to fix onto any gutter system with integrated fold down screw tabs for efficient and secure installation.

Featuring 4 tabs per linear metre, (see right for configuration), precision welded and constructed from the same high grade stainless steel.

The tabs provide a sturdy mount and fix point as well as helping to position the spikes during installation.

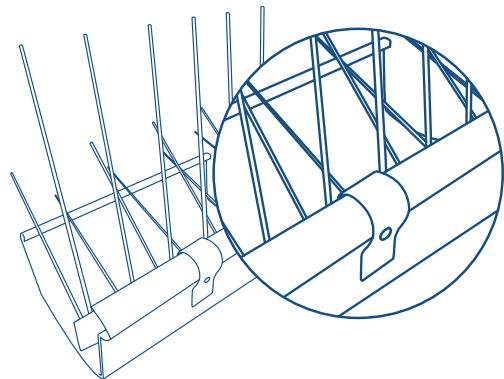

Proprietary (intergrated) mounting tab that folds over any spout lip

SUPPORT

VEXO spikes can be custom manufactured to suit unique projects.

Contact **+61 3 9458 5118** for any assistance in solution evaluation and product recommendation.

Free literature, catalogue and installation information is available.

MODEL SPECS

GX21

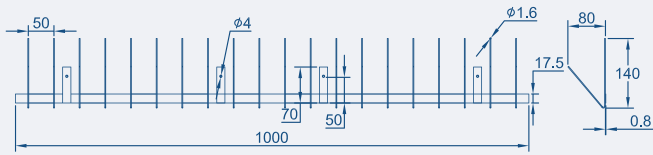

GX33

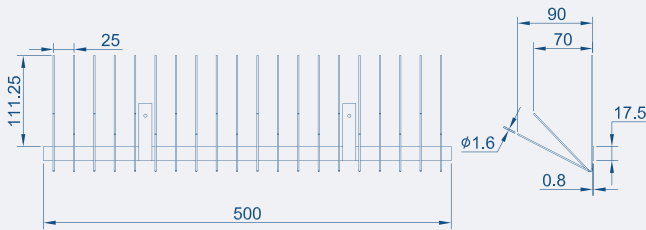

FEATURES AND BENEFITS

Prevents Birds from Perching on or Nesting in Gutters	✓
Deters Possums and Rodents from Climbing onto Roofs	✓
100% High Grade SUS304 Stainless Steel for Durability	✓
Integrated Fold Down Screw Tabs for Easy, Fast and Secure Installation	✓
Does Not Harm Birds	✓
Resist UV Degradation and Corrosion	✓

PRODUCT DATA

Product Name	GX21	GX33
Width	80mm	90mm
Length	1000mm	500mm
Height	140mm	
Base Width	17.5mm	
Pitch	50mm	25mm
Weight	216g	146g
Spike Material	SUS304 Stainless Steel	

TARGET PESTS

Pigeons	✓	Sparrows	
Mynas		Swallows	
Starlings		Seagulls	
Galahs	✓	Cockatoos	✓
Magpies	✓	Rodents & Possums	✓

APPLICATION

Parapets		Fences	✓
Signages		Awnings	
Beams		Gutters	✓
Ledges		Roofs	
Cornices		Pipes	

QUALITY ASSURANCE

Every 30 metres of bird spikes undergoes extreme destructive test to ensure the weld and form quality is maintained.

PRODUCT HANDLING

VEXO spikes are packaged for fast and safe on site installation. Handle VEXO spikes from the base strip. Protect VEXO spikes from damage before, during and after installation.

If damage occurs to VEXO spikes, replace section immediately.

WARRANTY

VEXO full stainless steel spikes are warranted against defects in materials and workmanship for 15 years.

Refer to our warranty policy for further information.